

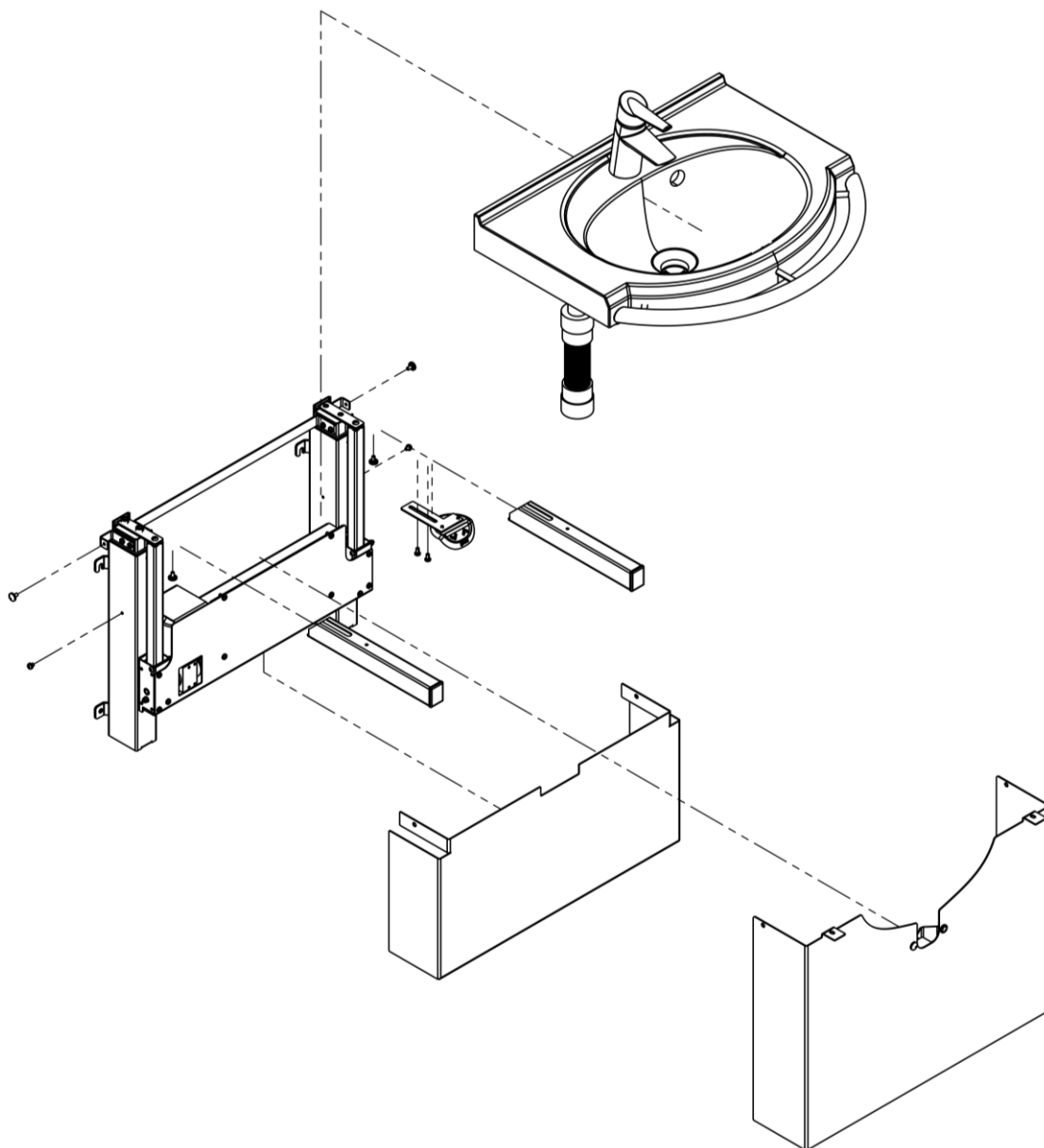



21273116-00 Electric Senior basin lifter installation guide



Description

ID	Item Revision	
D012226	A.3	
Type	Installation instructions	
Subject		
Owner	korpinen_admin	
Owning Group	Korpinen	

Symbols used in this manual

Warning! Indication of potentially hazardous situation. If not avoided, it can result in serious injury or death.	
Caution! Indication of potentially hazardous situation which may result in minor or moderate injury. It may also be used to alert against unsafe practices.	
Notification! This symbol is used to notify correct use and handling of the product.	

General safety

	<p>This manual must be read and understood before use and installation. Always keep this manual in close proximity of the product.</p> <p>The use, installation and service of this product must follow this manual to avoid accidents and serious personal injury.</p> <p>Never use or handle this product in other ways specified in this manual as it can result in personal safety hazards and/or cause damage to the product.</p> <p>Persons installing and/or using this product either as operator or user should have the necessary safety information and access to this manual.</p> <p>If the supply cord is damaged, it must be replaced by the manufacturer, its service agent or duly qualified designated persons in order to avoid a hazard.</p>
---	---



Do not perform unauthorized repairs, disassembly or assembly operations, add-ons, re-adjustments or modification of the product beyond what is described in this manual. Any use, modification or adjustment not described in the most recent approved revision of the manual is strictly forbidden. Do not perform service while the product is connected to the mains power.

This appliance can be used by children aged from 8 years and above and persons with reduced physical, sensory or mental capabilities or lack of experience and knowledge if they have been given adequate supervision or instruction concerning the safe use of the appliance and they understand the hazards involved. Children shall not play with the appliance. Cleaning and user maintenance shall not be performed by children without supervision.

Do not use the product if it has defects or signs of damage are present. If the device makes unusual noise or smells, switch off the mains voltage immediately.

Take care that the cables are not damaged. Unplug the mains cable on mobile equipment before it is moved.













The products must only be used in an environment that corresponds to their IP protection.



The information in this manual is based on correct installation in accordance with installation instructions for this product.

Korpinen cannot be held liable if the product is used in any way that differs from stated in this manual and/or installation instruction. Korpinen reserves the right to amend this manual and reference documents without prior notice.

Product label symbols

	<p>This product is CE-marked in accordance with:</p> <p>Council Directive 2006/42/EC on machinery</p> <p>Council Directive 2011/65/EU, RoHS</p>
	<p>Manufacturer name and address</p>
	<p>Date of production</p>
	<p>Stock number</p>
	<p>Serial number</p>
	<p>Consult manual before use</p>
	<p>Operating interval of electrically operated equipment. The use of electrical height adjustable equipment can run at maximum 2 minutes, followed by an 18-minute break.</p>
	<p>Type B applied part. The product complies with IEC 60601-1 requirements to provide protection against electric shock.</p>
	<p>Consult manual for important safety related information, warnings, and safety precautions.</p>
	<p>Class II, double isolated electrical components.</p>
	<p>Do not dispose as unsorted municipal waste. Product must be returned to a designated recycling station.</p>
	<p>Mobile phones or other portable RF emitting equipment should be no closer to the product than 30cm.</p>
	<p>Operating and storing temperatures may not exceed 5-40°C</p>

Exploded view

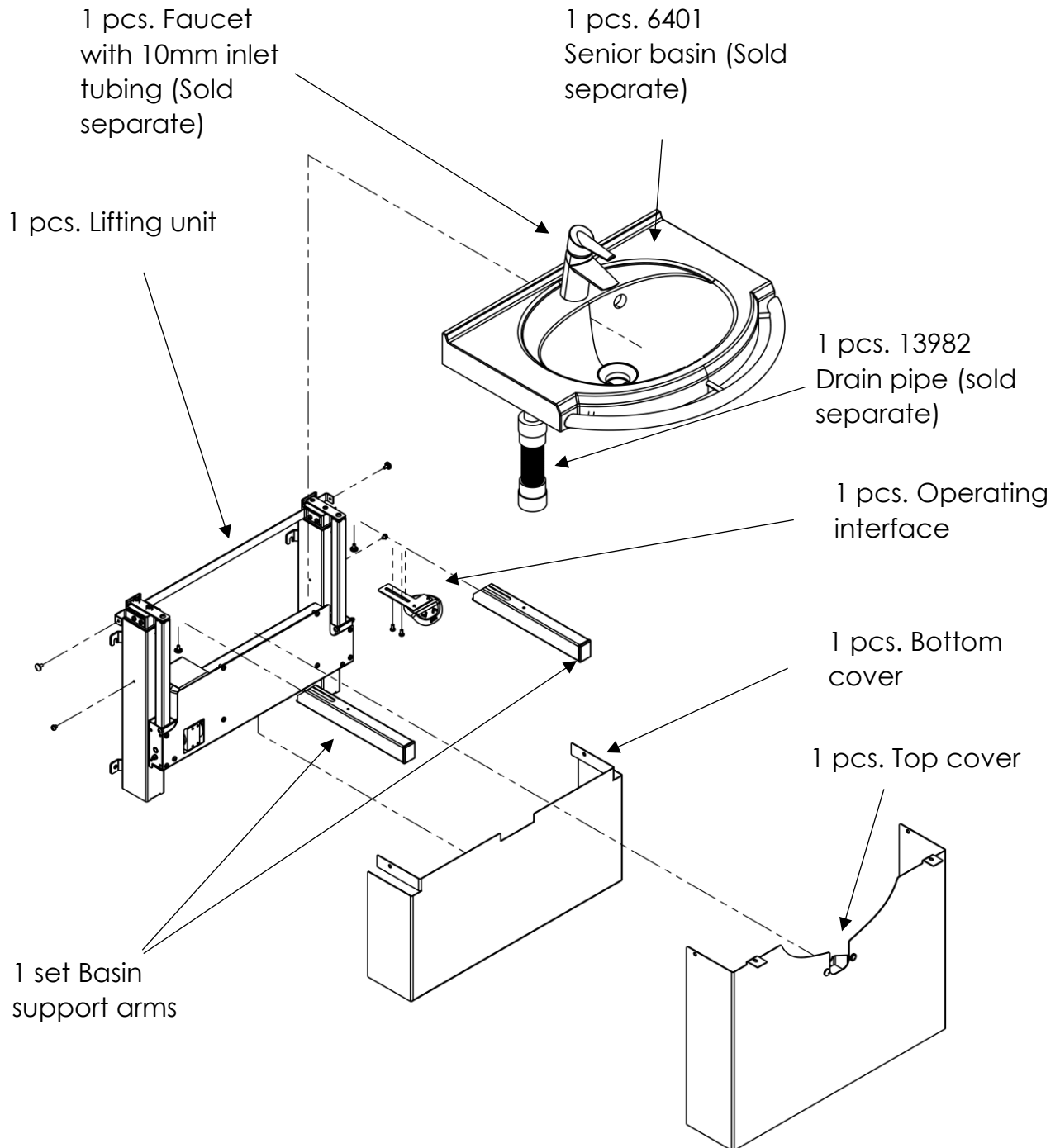

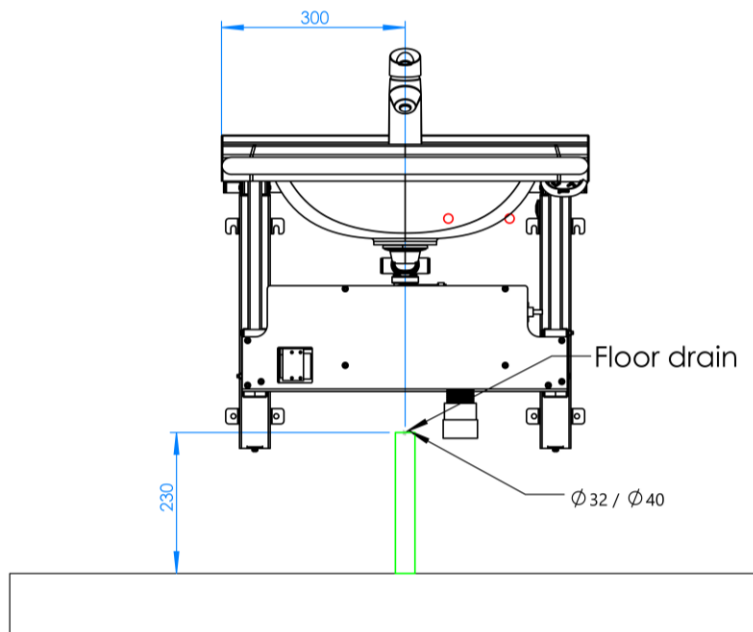
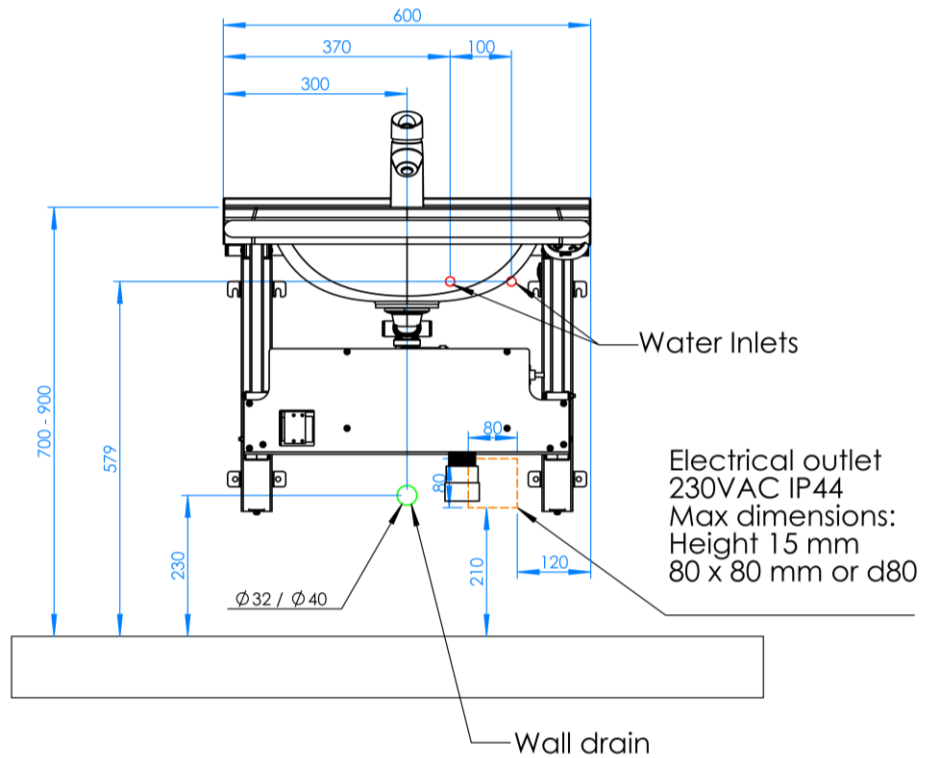

IMPORTANT NOTICE! Floor drain should extend at least 230 mm from the floor. Tube diameter 32 – 40 mm. Tube center distance from wall 50-60 mm.

Figure 1. Water inlet, drain and mains power placement

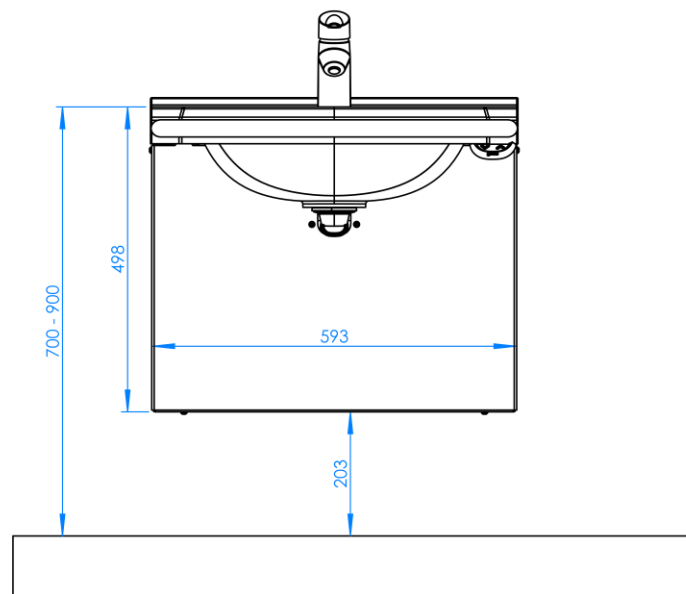
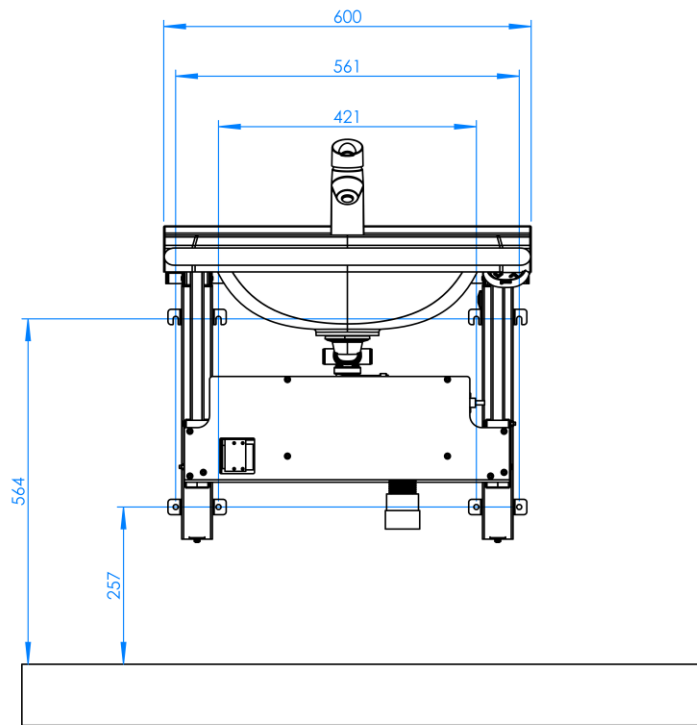

Figure 2. Unit mounting hole placement and external dimensions

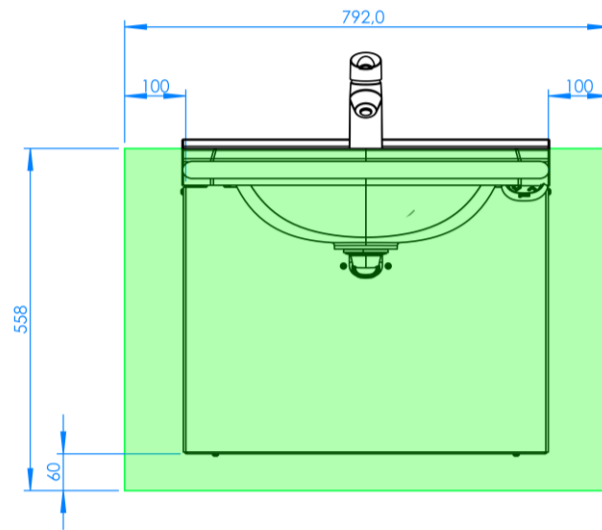
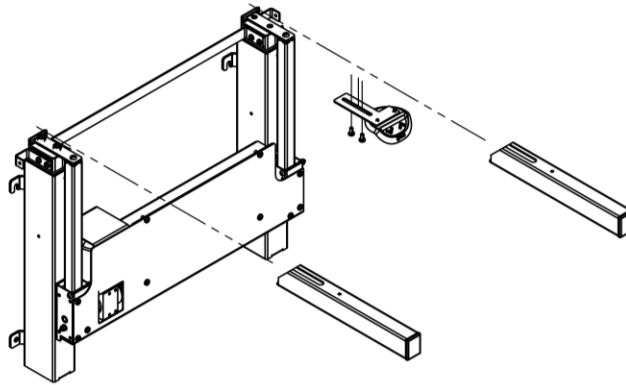
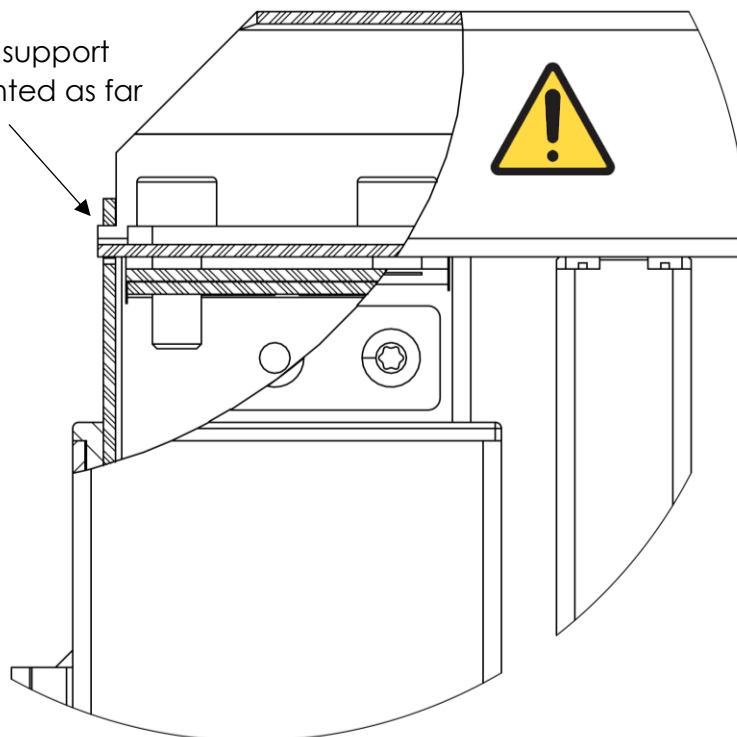

Figure 3. Reinforced area (20 mm plywood with full thread screws)

1. Install the basin support arms and the operating interface



Make sure the support arms are mounted as far as they will go.



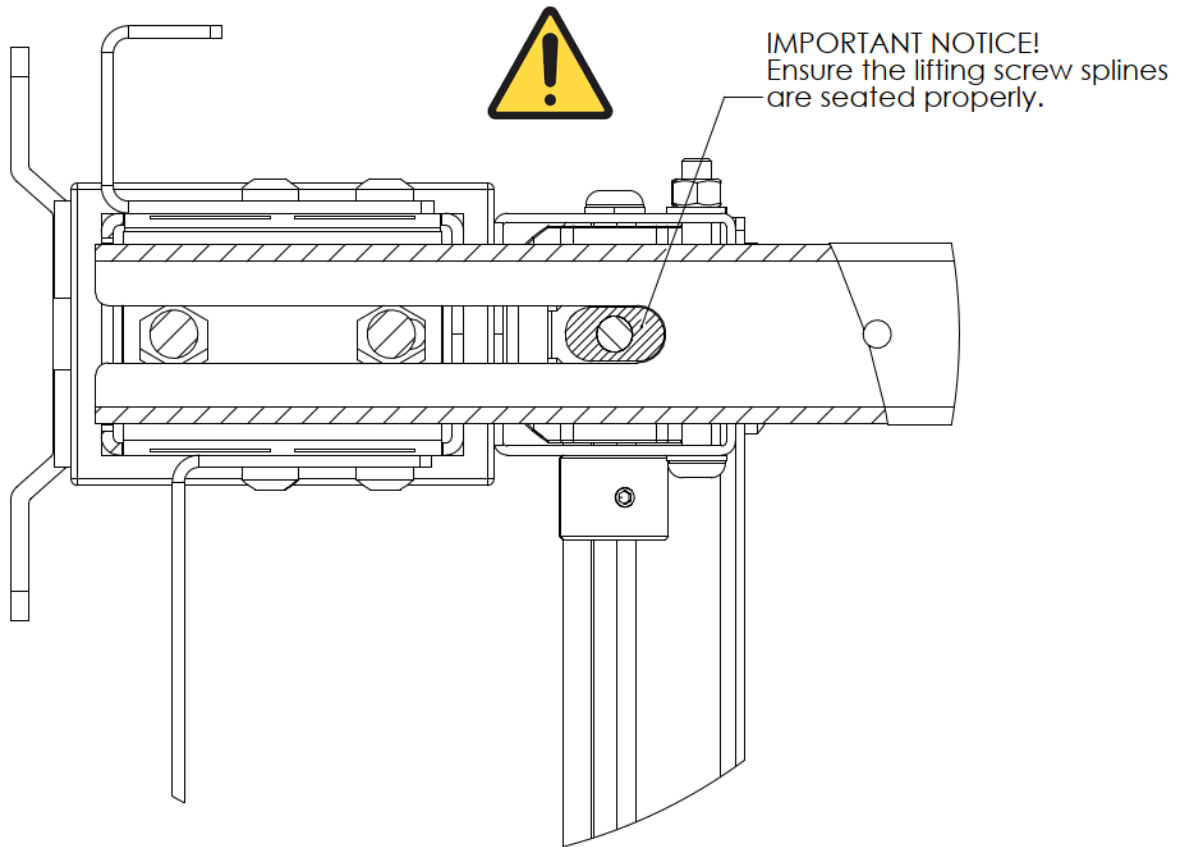

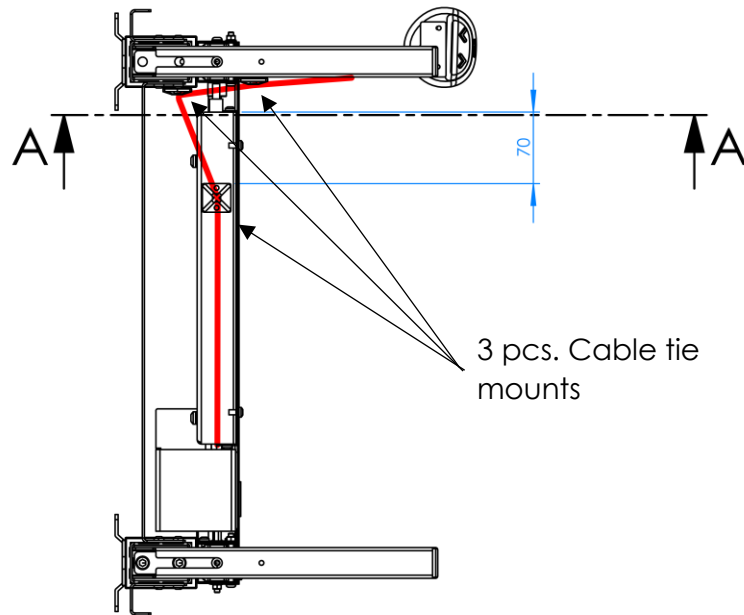

Install the cable tie mounts and route the controller wiring as pictured. Leave a 140-150 mm loop of wire between the leg and basin support arm

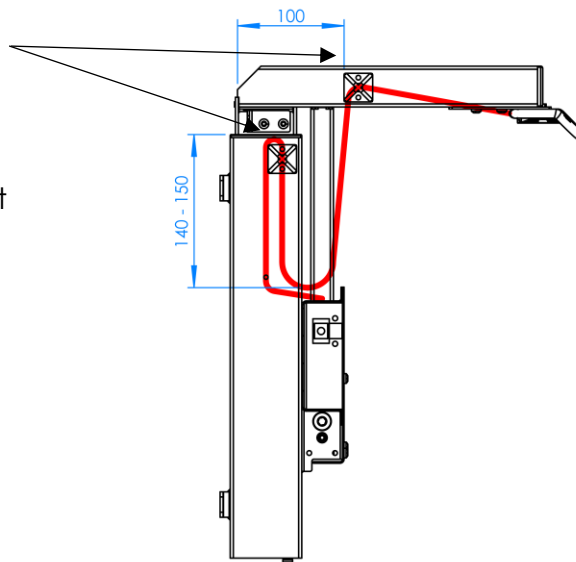

SECTION A-A

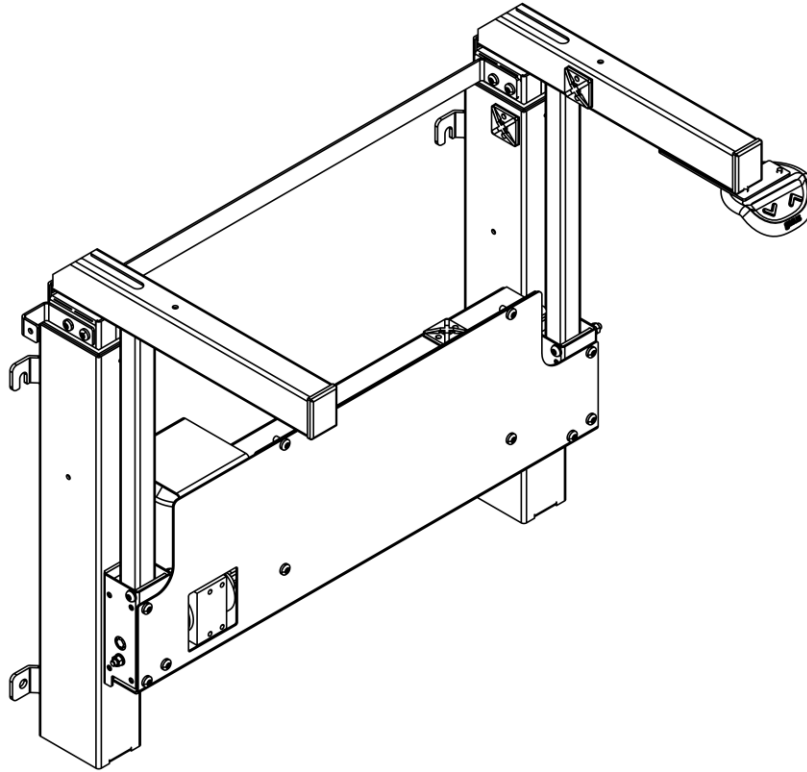

2. Pre-drill all necessary holes. Refer to Fig. 2 for mounting hole positions. Install the top mounting screws into the wall.

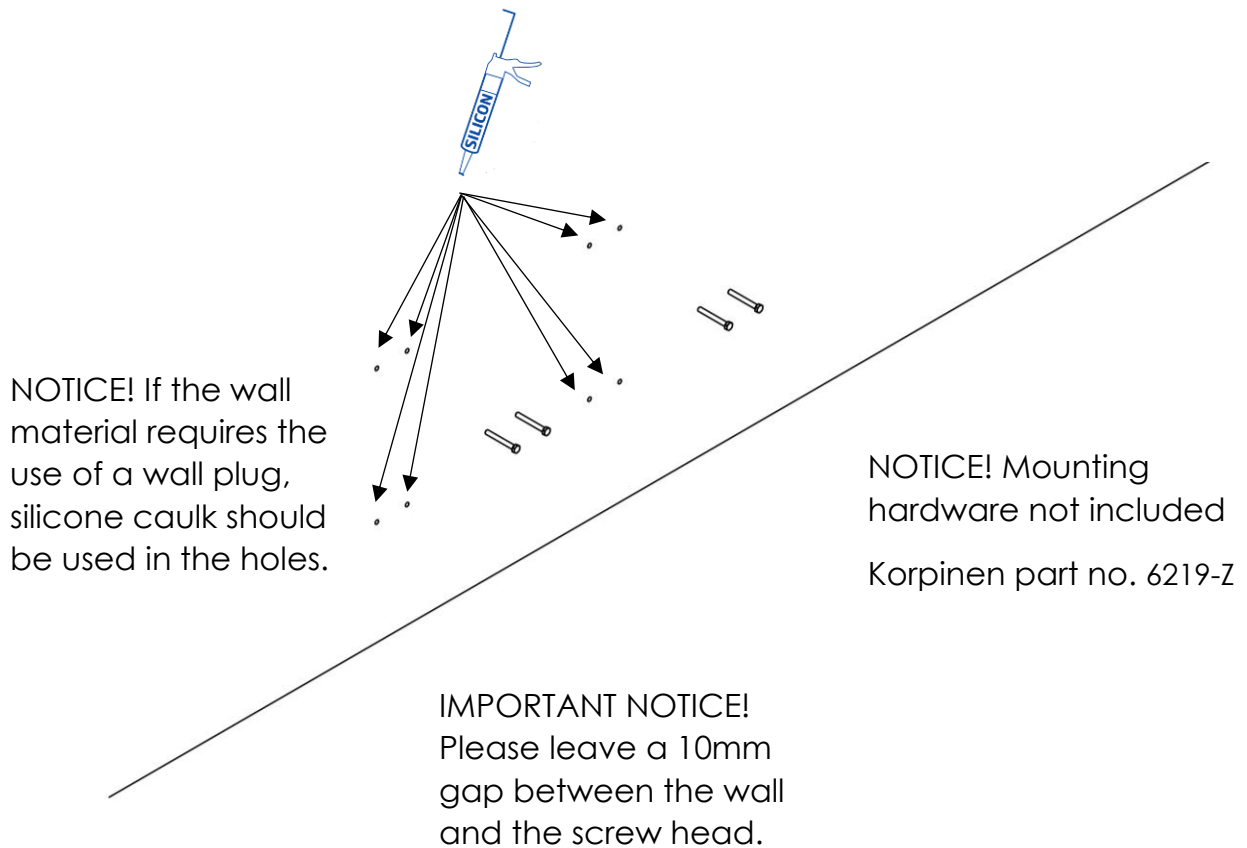

3. Lift the basin lifter on top of the top screws in the wall.
Using a spirit level, ensure that the unit is installed level.

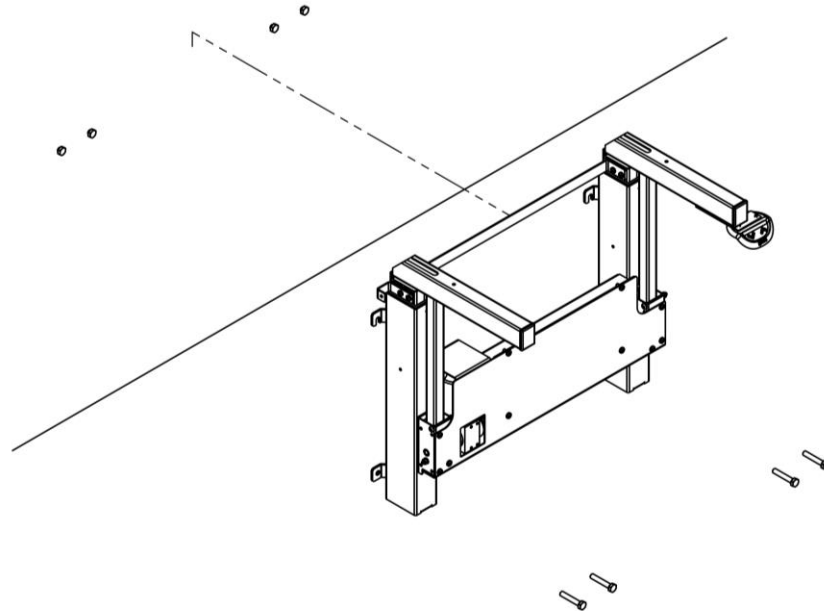

4. When the unit is level, tighten the top screws; insert and tighten the bottom screws. Plug the lifter to mains power and test the lifter before adhering the basin.

IMPORTANT NOTICE! Use a spirit level to ensure the unit is installed level

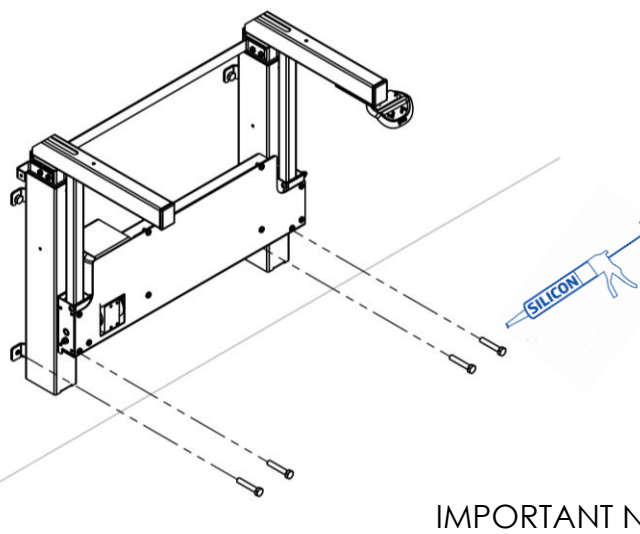

IMPORTANT NOTICE! While testing, keep hands and tools away from the open mechanism. Before continuing work, unplug the unit.

IMPORTANT NOTICE! Test the unit before moving to the next step.

5. Assemble the faucet, basin and plumbing

IMPORTANT NOTICE! The faucet must have 10mm inlet tubing

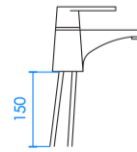
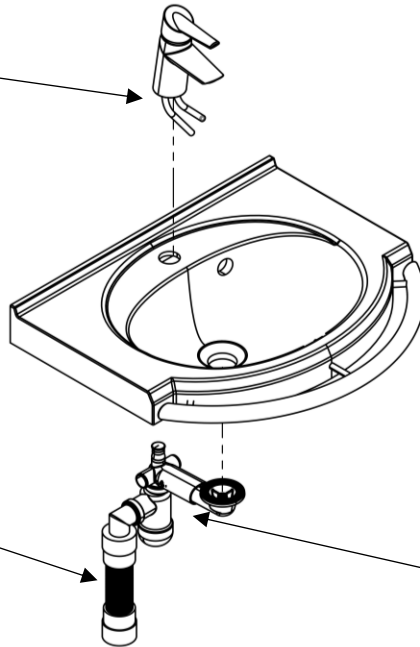

IMPORTANT NOTICE!
Cut the faucet tubes to 150 mm. Faucet sold separate.

NOTICE! 13982 Flexible drain pipe sold separate.

NOTICE! Air lock must be pressed and fixed to the top position with a cable tie. Flexible drain pipe must be held in place with hose clamp.

NOTICE! Cut the air lock plumbing to size

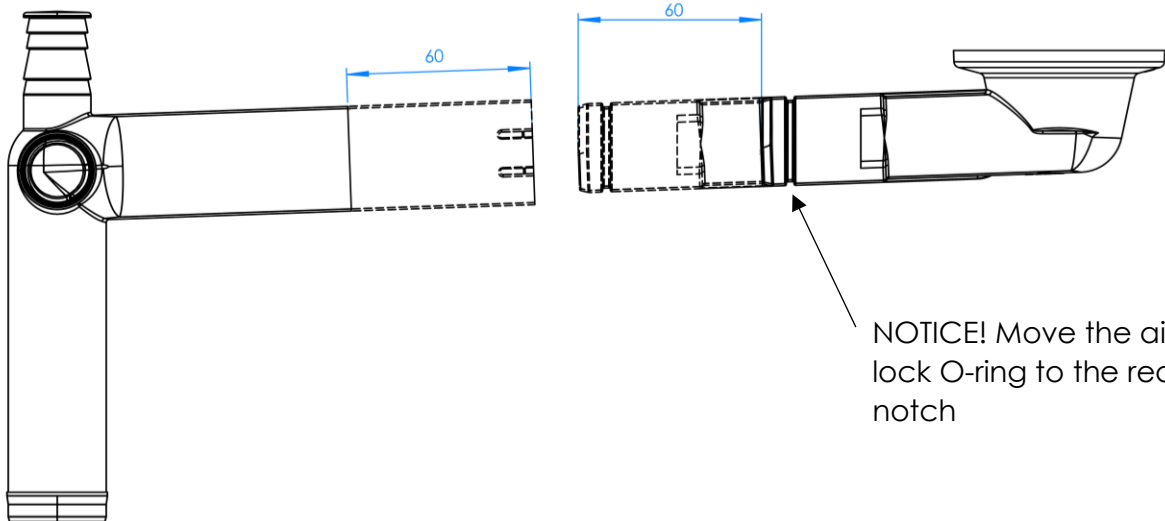

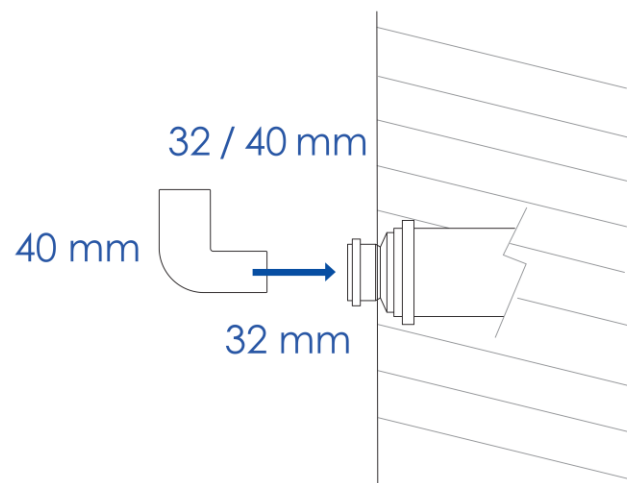
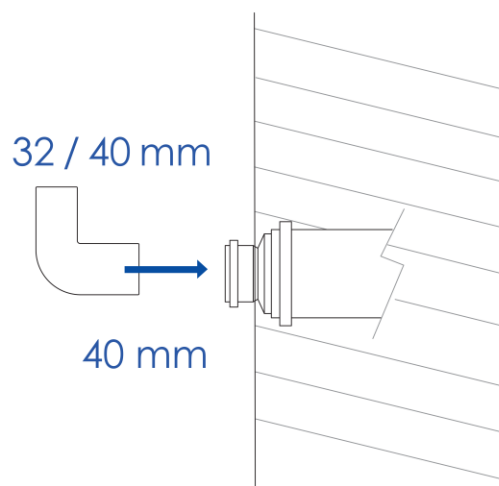
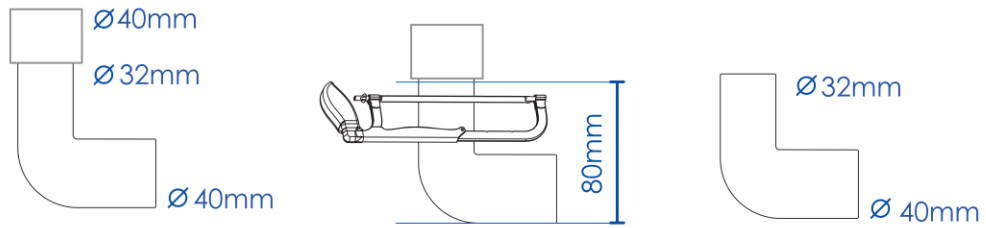

6. After testing the unit and cleaning the underside of the basin, adhere the basin to the lifter frame and install the plumbing.

IMPORTANT NOTICE! The bond will be permanent

Use Sikaflex FC11 to adhere the basin

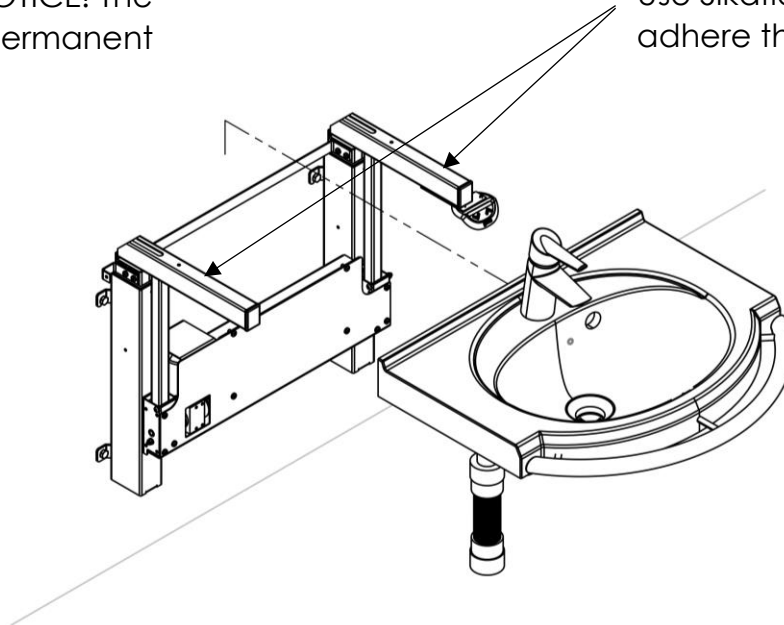

IMPORTANT NOTICE! Make sure to leave a 5 – 8 mm gap between the basin and any walls next to it

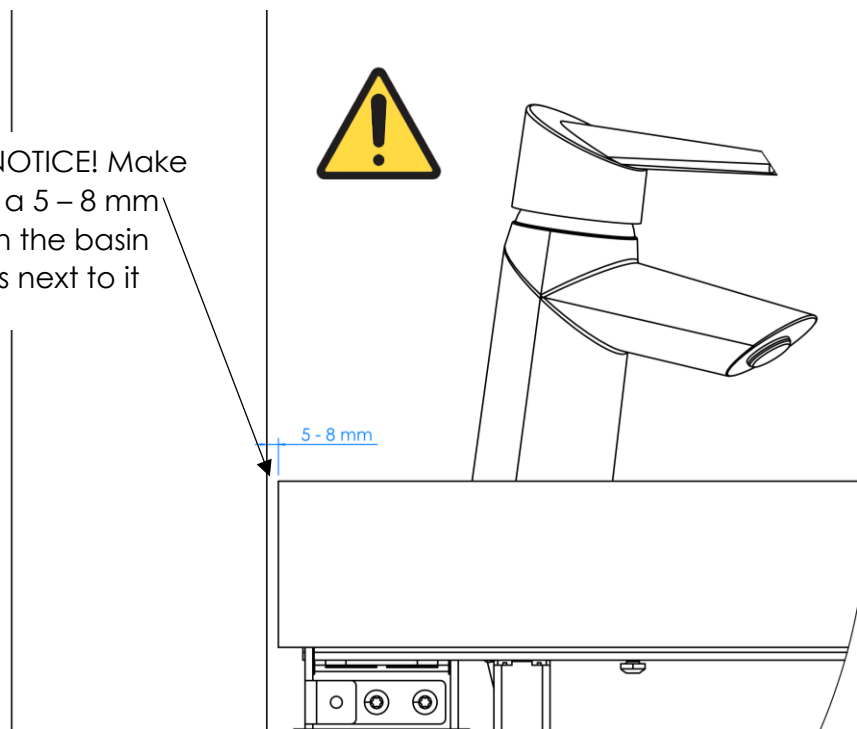

IMPORTANT NOTICE! The faucet tubes should be bent in the manner displayed. The tubes should be 65mm from the wall.

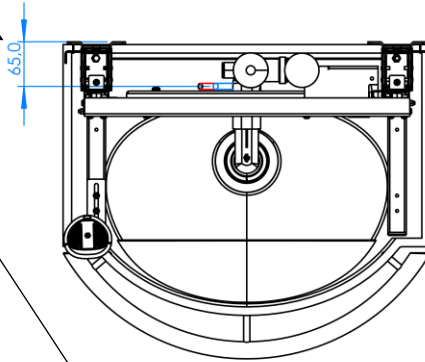

13970 Water hoses, connectors and brackets package (sold separate) contains: 2 pcs. Hose L500 G1/2, 2 pcs. G1/2 10mm Cut-off valves and 2 pcs. Hose brackets

2x Hose brackets

IMPORTANT NOTICE! The water inlet points must not protrude more than 45 mm from the wall. The openings must point towards the floor

Hose: L500 G1/2 or Total L650-700mm

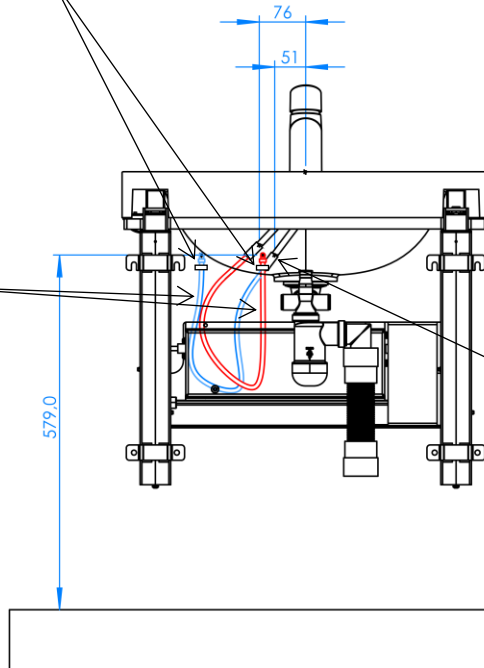

2x G1/2 10mm Cut-off valve

Figure 4. Plumbing view is viewing from the back side of the unit

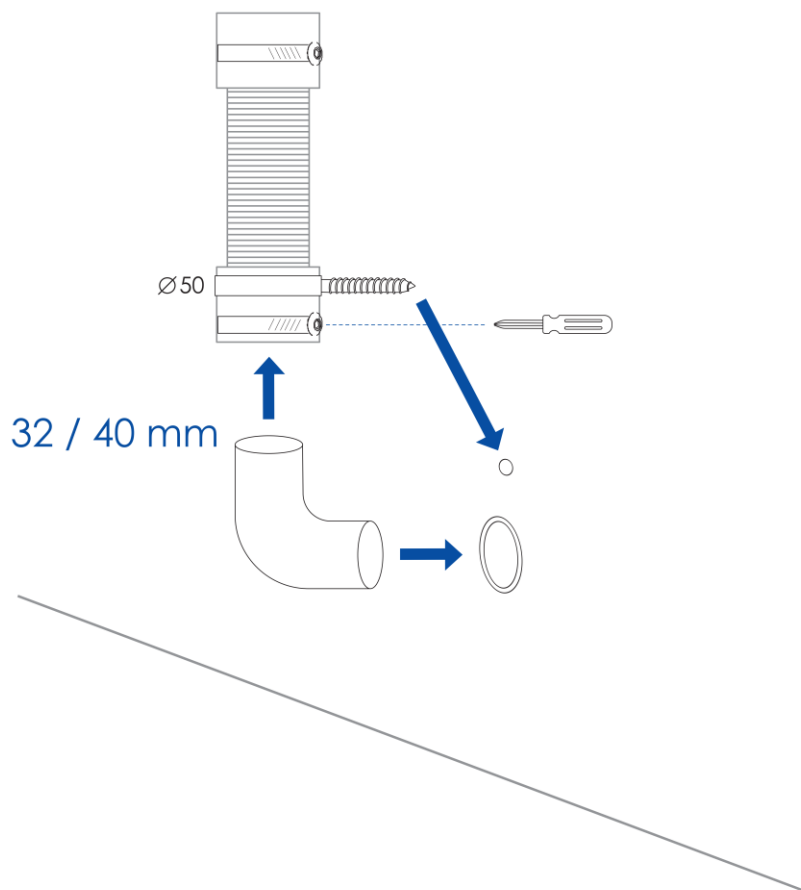

7. Install the bottom cover and tuck the excess mains wire

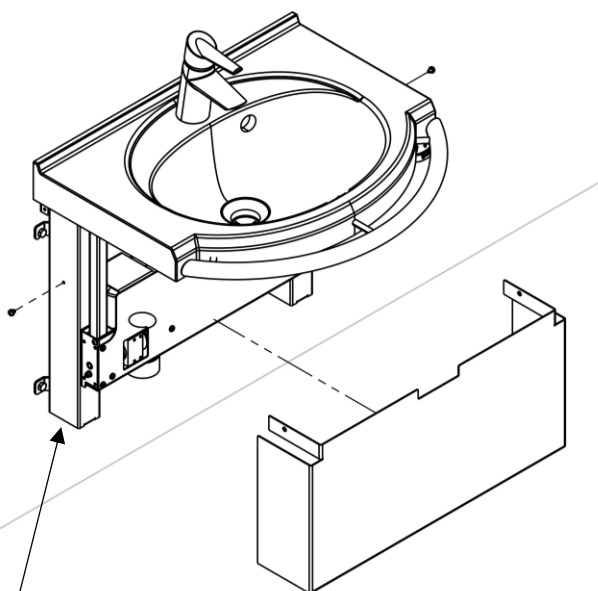

IMPORTANT NOTICE!
Mind the bottom screws when sliding the bottom cover to place; remember to tighten the bottom screws.

Using the supplied cable ties and cable tie mounts, mount the excess power cord to the specified area on the bottom cover.

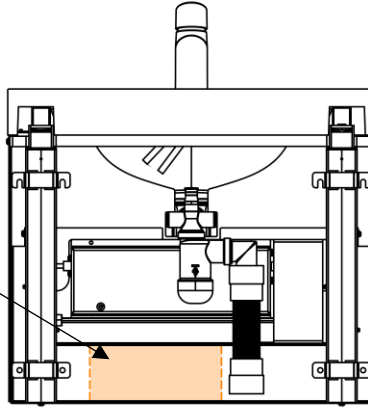

IMPORTANT NOTICE!
Do not tie the cables outside of the specified area

8. Install the top cover and test the unit to ensure full functionality

